

**MAXIM**

# Step-Up/Down DC-DC Converter in QSOP Package

**MAX1672**

## General Description

The MAX1672 integrates a step-up DC-DC converter with a linear regulator to provide step-up/down voltage conversion. This device provides a constant output voltage for inputs that vary above and below the output voltage. It has a 1.8V to 11V input range and a preset 3.3V or 5V output. The output can also be set from 1.25V to 5.5V using two resistors. Typical efficiency is 85%.

The MAX1672's step-up/linear-regulator configuration permits the use of a single, physically smaller inductor than can be used with competing SEPIC and flyback configurations. Switch current is also selectable, permitting the use of smaller inductors in low-current applications. The linear regulator also acts as a filter to reduce output ripple voltage.

The MAX1672 has a low 85 $\mu$ A quiescent supply current, which is further reduced to 0.1 $\mu$ A in logic-controlled shutdown. The output voltage is disconnected from the input in shutdown. The MAX1672 also has a PGI/PGO low-battery detector.

The MAX1672 comes in a 16-pin QSOP package (same size as a standard 8-pin SO). For a larger device that delivers more output current, refer to the MAX710/MAX711. The preassembled MAX1672 evaluation kit is available to speed designs.

## Applications

Single-Cell, Lithium-Powered Portable Devices      2-Cell to 4-Cell AA Alkaline Hand-Held Equipment

3.3V and Other Low-Voltage Systems                  Battery-Powered Devices with AC Input Adapters

Digital Cameras

## Typical Operating Circuit

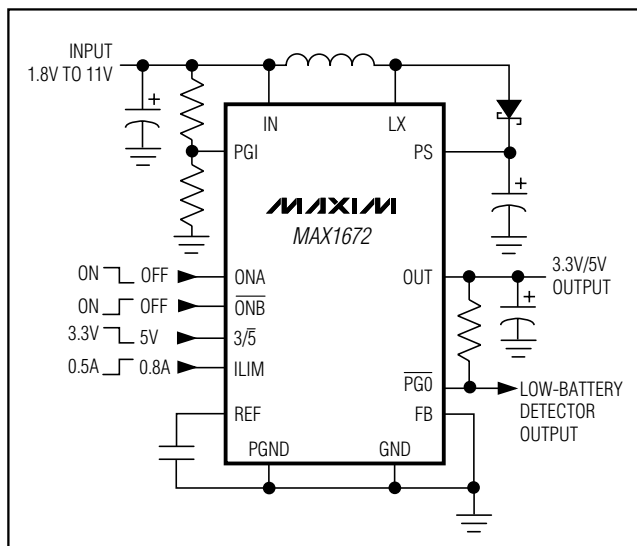

## Features

- ◆ Step-Up/Down Voltage Conversion
- ◆ 1.8V to 11V Input Range
- ◆ 3.3V/5V or Adjustable Output Voltage Range
- ◆ Output Current:
  - 300mA at 5V ( $V_{IN} \geq 2.5V$ )
  - 150mA at 5V ( $V_{IN} \geq 1.8V$ )
- ◆ Smaller Inductor than SEPIC and Flybacks
- ◆ Load Disconnects from Input in Shutdown
- ◆ Supply Current from Battery:
  - 85 $\mu$ A (No-Load)
  - 0.1 $\mu$ A (Shutdown)
- ◆ PGI/PGO Low-Battery Comparator
- ◆ 16-Pin QSOP Package (Same Footprint as 8-pin SO)
- ◆ No External FETs Required
- ◆ Thermal and Short-Circuit Protection

## Ordering Information

PART	TEMP RANGE	PIN-PACKAGE
MAX1672C/D	0°C to +70°C	Dice*
MAX1672EEE	-40°C to +85°C	16 QSOP

\*Dice are tested at  $T_A = +25^\circ\text{C}$ .

## Pin Configuration

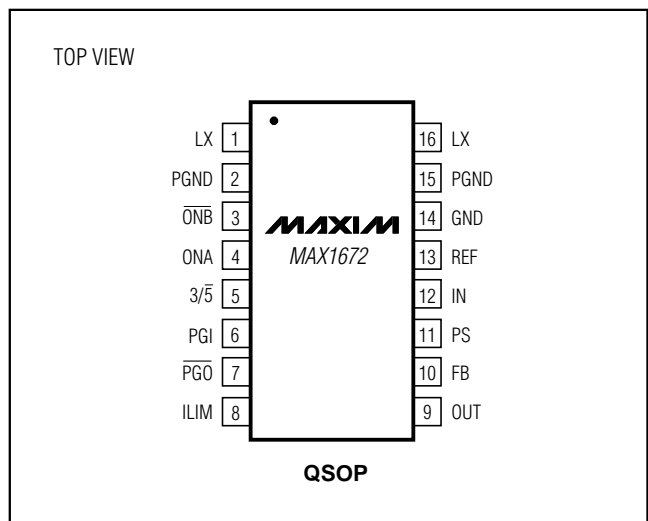
**MAXIM**

Maxim Integrated Products 1

For pricing, delivery, and ordering information, please contact Maxim/Dallas Direct! at 1-888-629-4642, or visit Maxim's website at [www.maxim-ic.com](http://www.maxim-ic.com).

# Step-Up/Down DC-DC Converter in QSOP Package

## ABSOLUTE MAXIMUM RATINGS

IN, PS, LX, OUT,  $\overline{\text{PGO}}$  to GND ..... -0.3V to +11.5V  
 ILIM, ONA,  $\overline{\text{ONB}}$ , FB, 3/5,  
 REF, PGI to GND ..... -0.3V to (V<sub>PS</sub> + 0.3V)  
 PGND to GND ..... -0.3V to +0.3V  
 OUT Short Circuit to GND ..... Continuous  
 Output Current ..... 350mA

Continuous Power Dissipation (T<sub>A</sub> = +70°C)  
 16-Pin QSOP (derate above +70°C by 8.3mW/°C) ..... 667mW  
 Operating Temperature Range ..... -40°C to +85°C  
 Junction Temperature ..... +150°C  
 Storage Temperature Range ..... -65°C to +160°C  
 Lead Temperature (soldering, 10s) ..... +300°C

Stresses beyond those listed under "Absolute Maximum Ratings" may cause permanent damage to the device. These are stress ratings only, and functional operation of the device at these or any other conditions beyond those indicated in the operational sections of the specifications is not implied. Exposure to absolute maximum rating conditions for extended periods may affect device reliability.

## ELECTRICAL CHARACTERISTICS

(V<sub>PS</sub> = 6V, C<sub>REF</sub> = 0.1μF, C<sub>OUT</sub> = 4.7μF, T<sub>A</sub> = -40°C to +85°C, unless otherwise noted. Typical values are at T<sub>A</sub> = +25°C.) (Note 1)

PARAMETER	CONDITIONS		MIN	TYP	MAX	UNITS		
Input Voltage			1.8		11.0	V		
Startup Voltage				0.9		V		
Output Voltage	FB = GND, I <sub>OUT</sub> = 0mA to 150mA	3/5 = GND V <sub>PS</sub> = 6.8V	T <sub>A</sub> = 0°C to +85°C		4.8	5.2	V	
			T <sub>A</sub> = -40°C to +85°C		4.75	5.00		5.25
		3/5 = PS	T <sub>A</sub> = 0°C to +85°C		3.17			3.43
			T <sub>A</sub> = -40°C to +85°C		3.13	3.30		3.47
Output Voltage Adjustment Range			1.25		5.5	V		
Output Load Regulation	V <sub>IN</sub> = 2V, 3/5 = GND, FB = GND, I <sub>OUT</sub> = 10mA to 150mA			0.003		%/mA		
Output Line Regulation	V <sub>IN</sub> = 3V to 5V, 3/5 = GND, I <sub>OUT</sub> = 100mA			0.15		%/V		
Quiescent Current	ON <sub>A</sub> = PS or $\overline{\text{ONB}}$ = GND, current measured into PS pin, I <sub>OUT</sub> = 0mA			85	125	μA		
Shutdown Quiescent Current	ON <sub>A</sub> = GND, $\overline{\text{ONB}}$ = PS, current measured into PS pin			0.1	1	μA		
Reference Voltage	I <sub>REF</sub> = 0mA		1.21	1.25	1.29	V		
FB Voltage	OUT = FB	T <sub>A</sub> = 0°C to +85°C		1.21	1.25	1.29	V	
		T <sub>A</sub> = -40°C to +85°C		1.20		1.30		
FB Dual-Mode Trip Threshold	Hysteresis = 15mV typical			70		mV		
FB Input Current	V <sub>FB</sub> = 1.3V			1	50	nA		
IN Input Current	V <sub>IN</sub> = GND to 11V			3	6	μA		
LX On-Resistance	V <sub>PS</sub> = 5.5V, I <sub>LX</sub> = 50mA			0.6	1.3	Ω		
	V <sub>PS</sub> = 2.7V, I <sub>LX</sub> = 50mA			0.9	2.0			
LX Leakage Current	V <sub>LX</sub> = 11V, ON <sub>A</sub> = GND, $\overline{\text{ONB}}$ = PS			0.1	1	μA		
LX Current Limit	ILIM = GND	T <sub>A</sub> = 0°C to +85°C		0.35	0.5	0.65	A	
		T <sub>A</sub> = -40°C to +85°C		0.3	0.5	0.7		
	ILIM = PS	T <sub>A</sub> = 0°C to +85°C		0.6	0.8	1.0		
		T <sub>A</sub> = -40°C to +85°C		0.5	0.8	1.1		
Output PFET Resistance	V <sub>PS</sub> = 5.5V, I <sub>OUT</sub> = 50mA			1.2	2.4	Ω		
	V <sub>PS</sub> = 2.7V, I <sub>OUT</sub> = 50mA			2.3	4.6			
Output PFET Leakage Current	V <sub>OUT</sub> = 0V, ON <sub>A</sub> = GND, $\overline{\text{ONB}}$ = PS			0.1	1	μA		
Output PFET Current Limit	V <sub>PS</sub> = 5.5V		0.35	0.7	1.4	A		

# Step-Up/Down DC-DC Converter in QSOP Package

MAX1672

## ELECTRICAL CHARACTERISTICS (continued)

( $V_{PS} = 6V$ ,  $C_{REF} = 0.1\mu F$ ,  $C_{OUT} = 4.7\mu F$ ,  $T_A = -40^\circ C$  to  $+85^\circ C$ , unless otherwise noted. Typical values are at  $T_A = +25^\circ C$ .) (Note 1)

PARAMETER	CONDITIONS	MIN	TYP	MAX	UNITS
Thermal Shutdown Threshold			150		$^\circ C$
Thermal Shutdown Hysteresis			20		$^\circ C$
<b>PGI/PGO COMPARATOR</b>					
PGI Input Bias Current	$V_{PGI} = 1.3V$		1	50	nA
Hysteresis			30		mV
PGI Threshold Voltage	$T_A = 0^\circ C$ to $+85^\circ C$	1.21		1.29	V
	$T_A = -40^\circ C$ to $+85^\circ C$	1.19	1.25	1.31	
$\overline{PGO}$ Output Leakage	$V_{PGO} = 11V$		0.1	1	$\mu A$
$\overline{PGO}$ Output Low Voltage	$I_{PGO} = 2mA$ , $V_{PGI} = 1.2V$		0.1	0.4	V
<b>LOGIC AND CONTROL INPUTS</b>					
Input Low Voltage	ONA, $\overline{ONB}$ , 3/5; ILIM			0.4	V
Input High Voltage	ONA, $\overline{ONB}$ , 3/5; ILIM	1.6			V
Input Bias Current	ONA, $\overline{ONB}$ , 3/5; ILIM		1	100	nA

**Note 1:** Specifications to  $-40^\circ C$  are guaranteed by design.

## Typical Operating Characteristics

( $T_A = +25^\circ C$ , unless otherwise noted.)

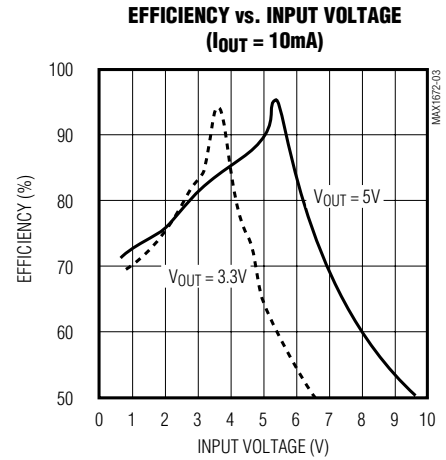
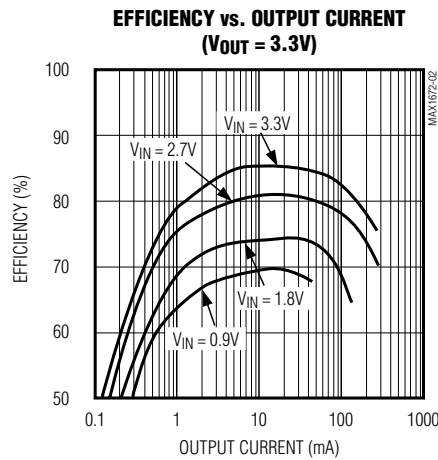
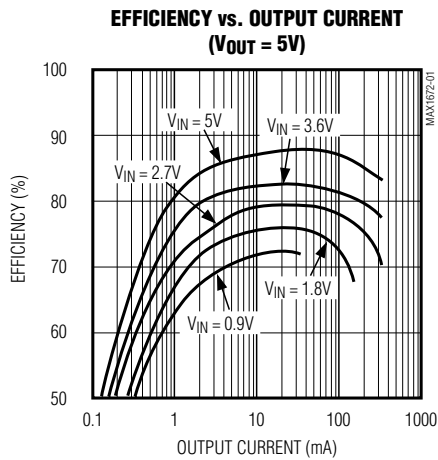

# Step-Up/Down DC-DC Converter in QSOP Package

## Typical Operating Characteristics (continued)

( $T_A = +25^\circ\text{C}$ , unless otherwise noted.)

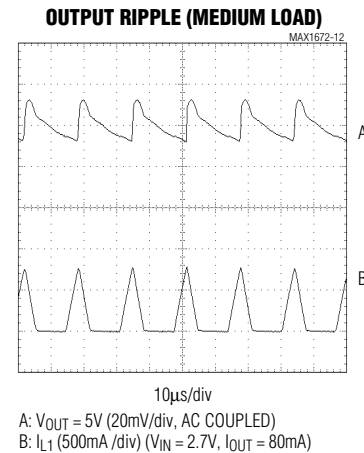
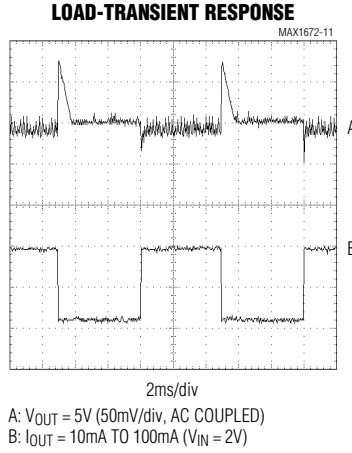
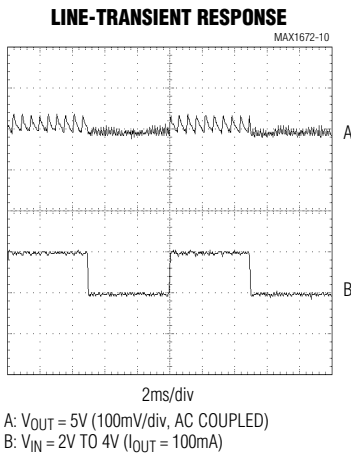
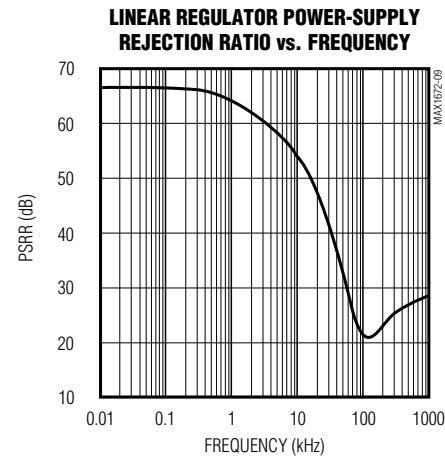
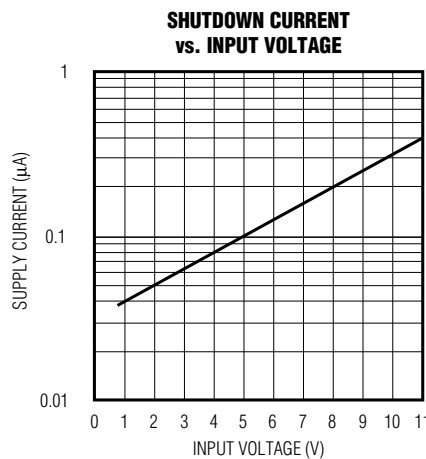
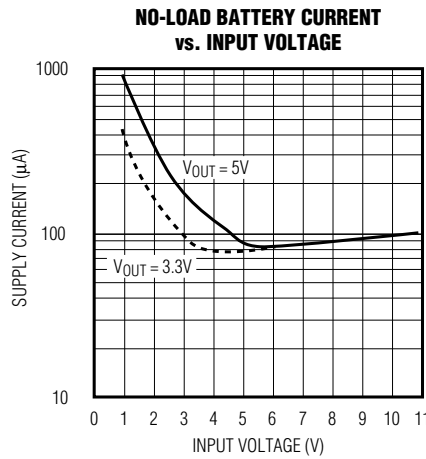
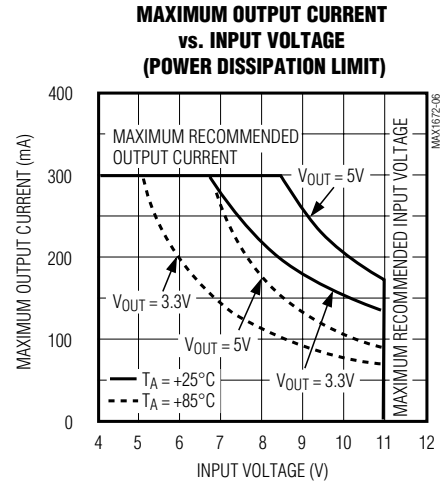
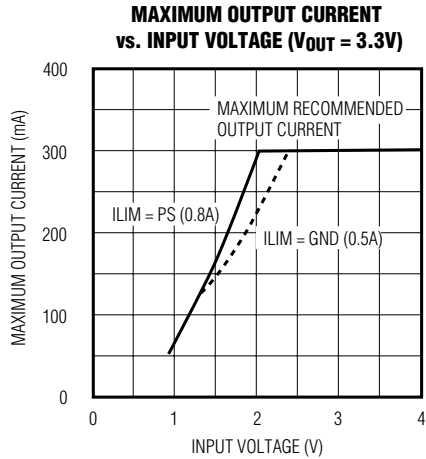
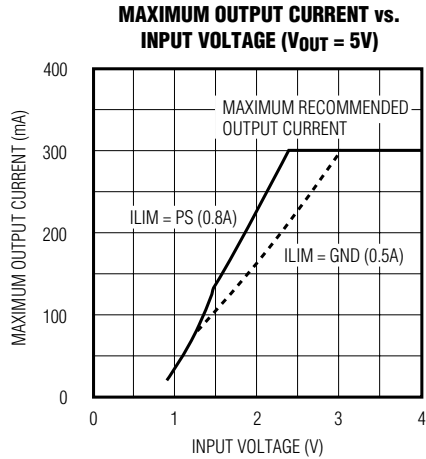

# Step-Up/Down DC-DC Converter in QSOP Package

MAX1672

## Typical Operating Characteristics (continued)

( $T_A = +25^\circ\text{C}$ , unless otherwise noted.)

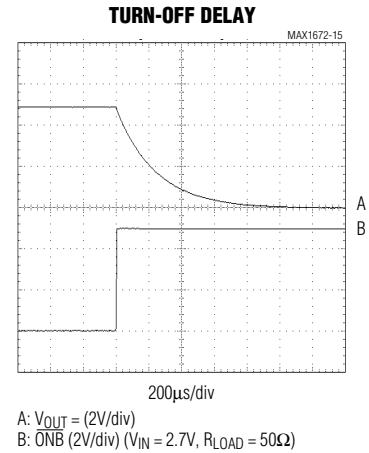
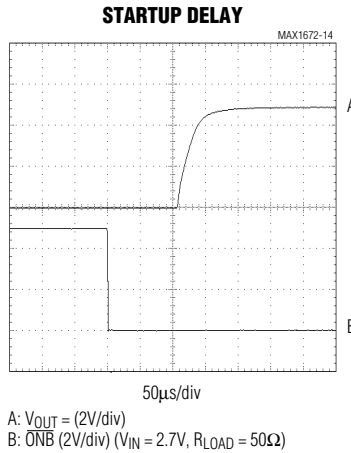
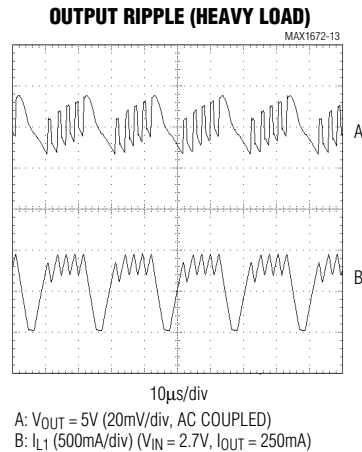

## Pin Description

PIN	NAME	FUNCTION
1	LX	Inductor Connection to the Drain of the Internal N-Channel Power MOSFET
2	PGND	Power Ground
3	$\overline{\text{ONB}}$	On Control Input. When $\overline{\text{ONB}} = \text{low}$ or $\text{ONA} = \text{high}$ , the IC is on. Connect $\overline{\text{ONB}}$ to GND for normal operation (Table 1).
4	ONA	On Control Input. When $\text{ONA} = \text{low}$ and $\overline{\text{ONB}} = \text{high}$ , the IC is off. Connect ONA to PS for normal operation (Table 1).
5	$3/\overline{5}$	Output Voltage Selection Input. Connect to PS for 3.3V output and to GND for 5V output. With $V_{FB} > 80\text{mV}$ , the state of the $3/\overline{5}$ pin is ignored (Table 2).
6	PGI	Low-Battery Detector Input (1.25V threshold)
7	$\overline{\text{PGO}}$	Low-Battery Detector Output (open drain). $\overline{\text{PGO}}$ pulls low when $V_{PGI}$ is greater than 1.25V.
8	ILIM	Inductor-Current-Limit Selection Input. Connect to PS for 0.8A current limit and to GND for 0.5A current limit.
9	OUT	Regulator Output. Drain of internal PFET linear regulator. Bypass with a 4.7µF capacitor to GND.
10	FB	Feedback Input. For 3.3V or 5V output, connect to GND. For adjustable output, connect to feedback resistor-divider network. With $V_{FB} > 70\text{mV}$ , the state of the $3/\overline{5}$ pin is ignored.
11	PS	Bootstrapped Power Supply. Output of step-up switch-mode regulator and source of internal PFET linear regulator. The IC is powered from this pin.
12	IN	Input Voltage Sense Input. Connect to input supply.
13	REF	Reference Voltage Output. Bypass with a 0.1µF capacitor to GND.
14	GND	Analog Ground
15	PGND	Power Ground
16	LX	Inductor Connection to the Drain of the Internal N-Channel Power MOSFET

# Step-Up/Down DC-DC Converter in QSOP Package

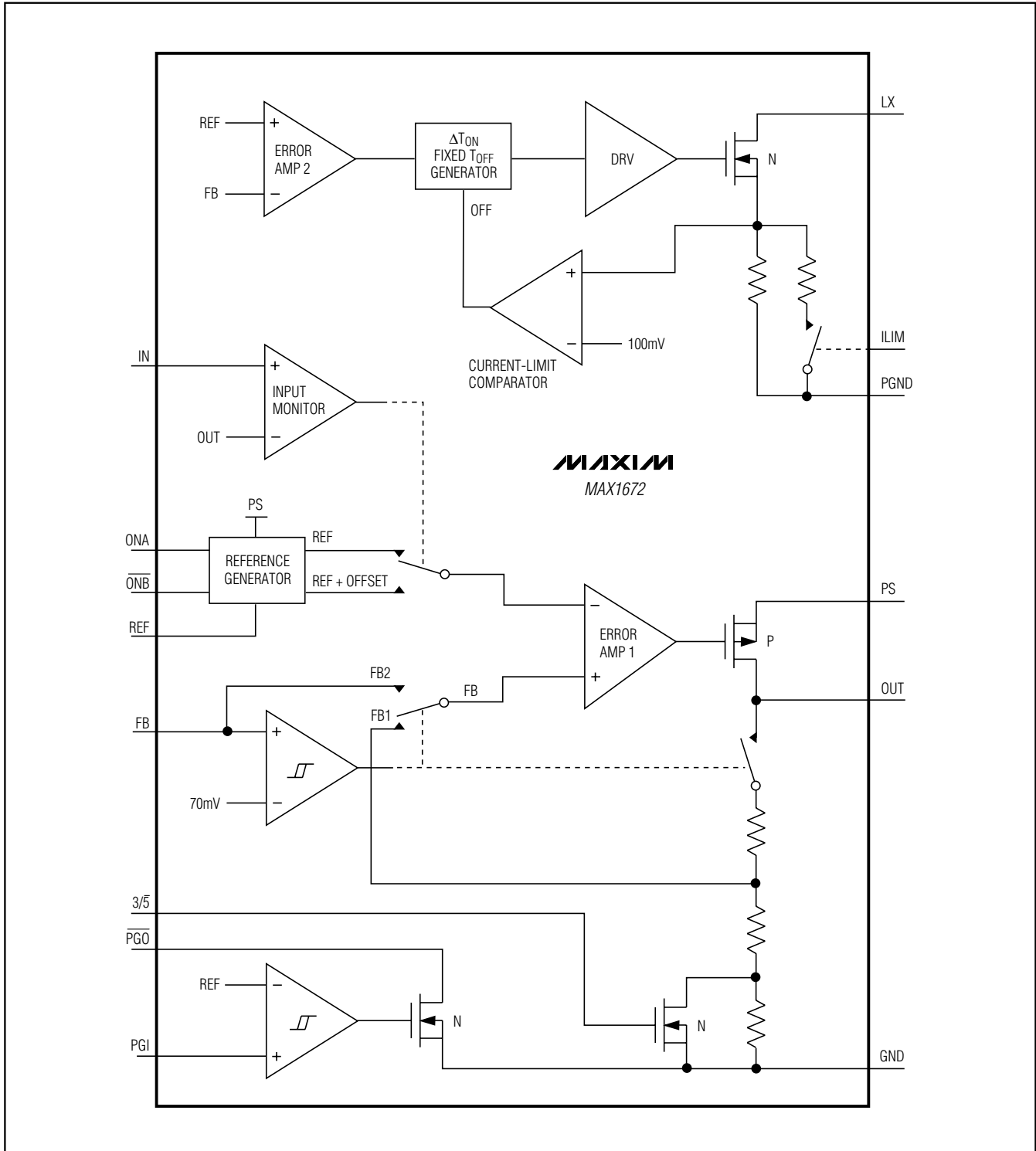

Figure 1. Functional Diagram

# Step-Up/Down DC-DC Converter in QSOP Package

## Detailed Description

The MAX1672 integrates a step-up, switch-mode DC-DC converter with a linear regulator to provide step-up/down voltage conversion. The step-up converter contains an N-channel power MOSFET switch, while the linear regulator contains a P-channel MOSFET pass element (Figure 1). The step-up converter and the linear regulator share the same precision voltage reference. The MAX1672's input range is from +1.8V to +11V, and the regulated output is internally preset to +3.3V or +5V, or can be adjusted with two external resistors. Boost efficiency typically exceeds 80% over a 2mA to 200mA load range. The device is bootstrapped with chip power derived from the stepped-up voltage output at PS. The MAX1672 typically starts up with a 0.9V input.

The MAX1672's step-up/linear-regulator configuration permits the use of a physically smaller inductor than competing SEPIC and flyback configurations because the  $\frac{1}{2}LI^2$  requirements of a step-up converter are half those of SEPIC and flyback converters. Also, high-frequency switching and selectable peak inductor current limit allow for low inductor value (10 $\mu$ H) and low current saturation rating, respectively, further reducing the inductor's physical dimensions.

The MAX1672 maximizes efficiency in both step-up and step-down operation. In step-up mode, when  $V_{IN} < V_{OUT}$ , only the step-up regulator is active, while the linear regulator behaves as a 1.2 $\Omega$  (at 5V output) PFET switch. This provides optimum efficiency (typically 85%).

In low-dropout, step-down operation, when  $V_{IN}$  is slightly greater than  $V_{OUT}$ , both the step-up regulator and linear regulator are active. The step-up regulator is automatically enabled to maintain headroom across the linear regulator (typically 1V above the 5V output). In this case, boost ripple is rejected by the linear regulator, and OUT remains in regulation with no dropout.

In normal step-down operation, when  $V_{IN}$  is significantly greater than  $V_{OUT}$ , only the linear regulator is active.

The mode of operation is automatically controlled on-chip through the IN pin, which compares  $V_{IN}$  and  $V_{OUT}$ . Transitions between step-up, low-dropout step-down, and normal step-down operation are stable, but can be seen as small variations in the output DC level and output ripple.

## Step-Up Switch-Mode Converter

A pulse-frequency-modulation (PFM) control scheme, with a constant 1 $\mu$ s off-time and variable on-time, controls the N-channel MOSFET switch. A pulse is initiated whenever OUT falls out of regulation. The N-channel switch then turns off when the inductor current reaches the peak current limit or after the 4 $\mu$ s maximum on-time, whichever occurs first. This control architecture provides high-efficiency, discontinuous inductor current under light loads as well as continuous inductor current under heavy loads. The switching frequency and output ripple are a function of load current and input voltage.

## Linear Regulator

The low-dropout linear regulator consists of a reference, an error amplifier, and a P-channel MOSFET. The reference is connected to the error amplifier input. The error amplifier compares this reference with the selected feedback voltage and amplifies the difference. The difference is conditioned and applied to the P-channel pass transistor's gate.

## ILIM

The current-limit-select input, ILIM, selects between the two peak inductor current limits: 0.8A (ILIM = PS) and 0.5A (ILIM = GND). If the application requires low output current (see *Typical Operating Characteristics*), select 0.5A. The lower peak current limit allows for a smaller, lower-cost inductor, and reduced output ripple.

## On/Off Control

The MAX1672 is turned on or off by logic inputs ONA and ONB (Table 1). When ONA = 1 or ONB = 0, the device is on. When ONA = 0 and ONB = 1, the device shuts down (see the *Applications Information* section). For normal (on) operation, connect ONA to PS and ONB to GND. Shutdown mode turns off the MAX1672 completely, disconnecting the input from the output and actively pulling OUT to GND.

**Table 1. On/Off Logic Control**

ONA	ONB	MAX1672
0	0	On
0	1	Off
1	0	On
1	1	On

# Step-Up/Down DC-DC Converter in QSOP Package

## Design Procedure

### Output Voltage Selection

For fixed output voltages of 3.3V or 5V, connect  $\overline{3/5}$  to PS or GND and connect FB to GND (Table 2). Alternatively, adjust the output voltage from 1.25V to 5.5V by connecting two resistors, R1 and R2 (Figure 2), which form a voltage divider between OUT and FB. Choose resistor values as follows:

$$R1 = R2[(V_{OUT} / V_{REF}) - 1]$$

where  $V_{REF} = 1.25V$ . Since the input bias current at FB has a maximum value of 50nA, R1 and R2 can be large with no significant accuracy loss. Choose R2 in the 100k $\Omega$  to 270k $\Omega$  range and calculate R1 using the above formula. For 1% error, the current through R1 should be at least 100 times FB's bias current.

Whenever the voltage at FB exceeds 70mV above GND, the state of the  $\overline{3/5}$  pin is ignored. Connect  $\overline{3/5}$  to GND when adjusting  $V_{OUT}$  with a resistor divider. Never leave  $\overline{3/5}$  unconnected.

### Low-Battery Detection

The MAX1672 contains a comparator for low-battery detection. If the voltage at PGI falls below  $V_{REF}$  (typically 1.25V), the open-drain comparator output ( $\overline{PGO}$ ) goes high. Hysteresis is typically 30mV. Set the low-battery detector's threshold with resistors R3 and R4 (Figure 2) using the following equation:

$$R3 = R4[(V_{PGT} / V_{REF}) - 1]$$

where  $V_{PGT}$  is the desired threshold of the low-battery detector and  $V_{REF} = 1.25V$ . Since the input bias current at PGI has a maximum value of 50nA, R3 and R4 can be large to minimize input loading with no significant accuracy loss. Choose R4 in the 100k $\Omega$  to 270k $\Omega$  range and calculate R3 using the above formula. For 1% error, the current through R3 should be at least 100 times PGI's bias current.

The  $\overline{PGO}$  output is open-drain and should be pulled high with external resistor R5 for normal operation. If the low-battery comparator is not used, connect PGI and  $\overline{PGO}$  to GND.

**Table 2. Output Voltage Control**

$\overline{3/5}$	FB	$V_{OUT}$ (V)
0	GND	+5
1	GND	+3.3
X	>70mV	+1.25 to +5.5

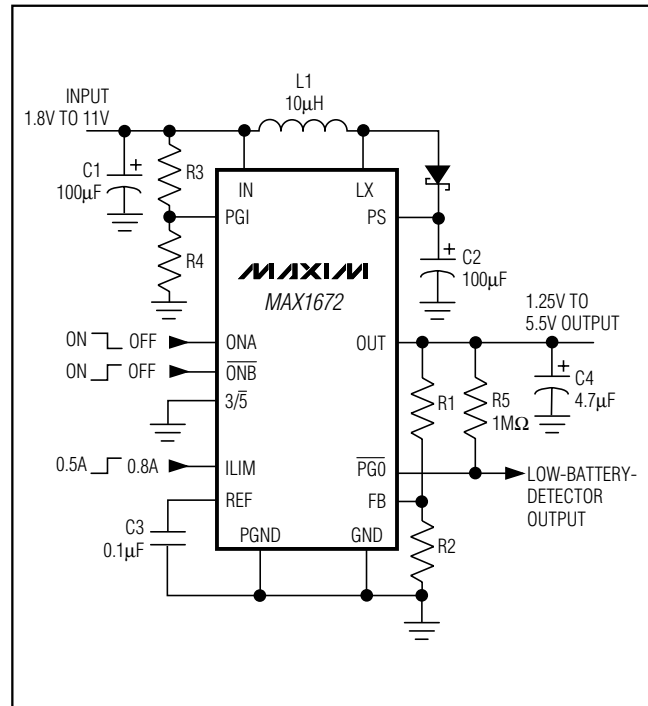

Figure 2. Adjustable Output Voltage Configuration

### Inductor Selection

A 10 $\mu$ H inductor performs well in most MAX1672 applications. Smaller inductor values typically offer a smaller physical size for a given series resistance, but may increase switching losses. Larger inductor values exhibit higher output current capability and larger physical dimensions for a given series resistance. For optimum performance, choose an inductor value from Table 3 or by using the following equation:

$$\frac{(V_{OUT} + V_{DIODE})}{I_{LIM}} t_{OFF} < L$$

$$< \frac{(V_{IN(min)} + V_{SWITCH})}{I_{LIM}} 2t_{ON(max)}$$

where  $I_{LIM}$  is the peak switch-current limit, which is 0.8A for  $I_{LIM} = PS$  and 0.5A for  $I_{LIM} = GND$ .

The inductor's incremental saturation current rating should also be greater than the peak switch-current limit. However, it is generally acceptable to bias most inductors into saturation by as much as 20% with slightly reduced efficiency. The inductor's DC resistance significantly affects efficiency. See Tables 4 and 5 for a list of suggested inductors and suppliers.



# Step-Up/Down DC-DC Converter in QSOP Package

MAX1672

**Table 3. Suggested Inductor Values**

$3\bar{5}$	ILIM	INDUCTOR VALUE ( $\mu$ H)
0 (5V)	0 (0.5A)	10 to 22
0 (5V)	1 (0.8A)	10
1 (3.3V)	0 (0.5A)	10
1 (3.3V)	1 (0.8A)	4.7 to 10

### Capacitor Selection

The equivalent series resistance (ESR) of both bypass and filter capacitors affects efficiency and output ripple. Output voltage ripple is the product of peak inductor current and filter capacitor ESR. Use low-ESR capacitors for best performance, or connect two or more filter capacitors in parallel.

A 100 $\mu$ F, 16V, input bypass capacitor (C1) with low ESR reduces peak battery currents and reflected noise due to inductor current ripple. Smaller ceramic capacitors may also be used for light loads or in applications that can tolerate higher input ripple.

A 100 $\mu$ F, 16V, surface-mount (SMT) tantalum PS filter capacitor (C2) with 0.1 $\Omega$  ESR typically exhibits 20mV output ripple (at OUT) when stepping up from 2V to 5V at 100mA load. Smaller capacitors (down to 10 $\mu$ F with higher ESR) are acceptable for light loads or in applications that can tolerate higher output ripple.

Only 4.7 $\mu$ F is needed at OUT (C4) to maintain linear regulator stability. During boost operation, this capacitor reduces output voltage spikes from the step-up converter by forming an R-C lowpass filter along with the P-channel MOSFET on-resistance. Output ripple can be further reduced by increasing C4.

See Tables 4 and 5 for a list of suggested capacitors and suppliers.

### Diode Selection

The MAX1672's high switching frequency demands a high-speed rectifier. Schottky diodes, such as the 1N5817 or MBRS130T3, are recommended. Make sure the diode's current rating exceeds the maximum load current. See Tables 4 and 5 for a list of suggested diodes and suppliers.

**Table 4. Suggested Components**

INDUCTORS	
L1 10 $\mu$ H	Sumida CD43-100 (1.04A, 0.182 $\Omega$ ) CD54-100 (1.44A, 0.100 $\Omega$ ) CDRH73-100 (1.68A, 0.072 $\Omega$ )
	Coilcraft DT1608C-103 (0.7A, 0.095 $\Omega$ )
CAPACITORS	
Tantalum	AVX TPSE Series
	Sprague 593D or 595D Series
DIODES	
Schottky	Motorola MBRS130LT3 (1.0A, 30V) MBR0520LT3 (0.5A, 20V)
	International Rectifier 10BQ40 (1.0A, 40V)
	1N5817 Equivalent

**Table 5. Component Suppliers**

SUPPLIER	PHONE	FAX
AVX	(803) 946-0690	(803) 626-3123
Coilcraft	(847) 639-6400	(847) 639-1469
International Rectifier	(310) 322-3331	(310) 322-3332
Motorola	(602) 303-5454	(602) 994-6430
Sanyo	(619) 661-6835	(619) 661-1055
Sprague	(603) 224-1961	(603) 224-1430
Sumida	(847) 956-0666	(847) 956-0702

# Step-Up/Down DC-DC Converter in QSOP Package

## Applications Information

### Using a Single, Pushbutton On/Off Switch

A single pushbutton switch can be used to turn the MAX1672 on and off. As shown in Figure 3, ONA is pulled low and  $\overline{\text{ONB}}$  is pulled high when the part is off. When the momentary switch is pressed,  $\overline{\text{ONB}}$  is pulled low and the regulator turns on. The switch should be on long enough for the  $\mu\text{C}$  to exit reset. The controller issues a logic high to ONA, which guarantees the part will stay on regardless of the switch state.

To turn off the regulator, press the switch again. The controller reads the switch status and pulls ONA low. When the switch is released,  $\overline{\text{ONB}}$  goes high, turning off the MAX1672.

### Thermal Overload Protection

Thermal overload protection limits total power dissipation in the MAX1672. When the junction temperature exceeds  $T_J = +150^\circ\text{C}$ , the pass transistor turns off, allowing the MAX1672 to cool. The pass transistor turns on again after the IC's junction temperature cools by  $20^\circ\text{C}$ , resulting in a pulsed output during thermal overload conditions.

Thermal overload protection is designed to protect the MAX1672 if fault conditions occur. It is not intended to be used as an operating mode. Prolonged operation in thermal shutdown mode may reduce the IC's reliability. For continual operation, do not exceed the absolute maximum junction temperature rating  $T_J = +150^\circ\text{C}$ .

### Power Dissipation and Operating Region

The MAX1672's maximum power dissipation in step-down mode depends on the thermal resistance of the case and circuit board, the temperature difference between the die junction and ambient air, and the air flow rate. The power dissipated in the device is  $P = I_{\text{OUT}}(V_{\text{IN}} - V_{\text{OUT}})$  during step-down operation. The maximum power dissipation is as follows:

$$P_{\text{MAX}} = (T_J - T_A)/(\theta_{\text{JB}} + \theta_{\text{BA}})$$

where  $(T_J - T_A)$  is the temperature difference between the MAX1672 die junction and the surrounding air,  $\theta_{\text{JB}}$  (or  $\theta_{\text{JC}}$ ) is the thermal resistance of the package, and  $\theta_{\text{BA}}$  is the thermal resistance throughout the printed circuit board, copper traces, and other materials to the surrounding air. The MAX1672's thermal resistance is  $120^\circ\text{C/W}$ . See the *Typical Operating Characteristics* for the Maximum Output Current vs. Input Voltage Graph.

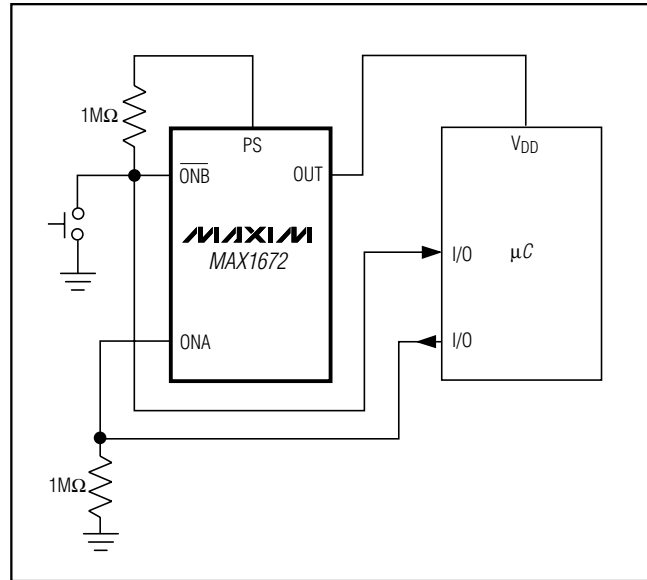

Figure 3. Momentary Pushbutton On/Off Control

### Layout Considerations

Proper PC board layout is essential to minimize noise due to high inductor current levels and fast switching waveforms. To maximize output power and efficiency and minimize output ripple voltage and ground noise, use the following guidelines when designing your board:

- Use a ground plane.
- Keep the IC's GND pin and the ground leads of C1 and C2 (Figure 2) less than 0.2in. (5mm) apart.
- Make all connections to the FB and LX pins as short as possible.
- Solder the IC's GND pin directly to the ground plane.

Refer to the MAX1672 EV kit for a suggested PC board layout.

# Step-Up/Down DC-DC Converter in QSOP Package

## Package Information

(The package drawing(s) in this data sheet may not reflect the most current specifications. For the latest package outline information go to [www.maxim-ic.com/packages](http://www.maxim-ic.com/packages).)

**MAX1672**

DIM	INCHES		MILLIMETERS	
	MIN	MAX	MIN	MAX
A	.061	.068	1.55	1.73
A1	.004	.0098	0.102	0.249
A2	.055	.061	1.40	1.55
B	.008	.012	0.20	0.31
C	.0075	.0098	0.191	0.249
D	SEE VARIATIONS			
E	.150	.157	3.81	3.99
e	.025 BSC		0.635 BSC	
H	.230	.244	5.84	6.20
h	.010	.016	0.25	0.41
L	.016	.035	0.41	0.89
N	SEE VARIATIONS			
X	SEE VARIATIONS			
Y	.071	.087	1.803	2.209
α	0°	8°	0°	8°

DIM	INCHES		MILLIMETERS		N
	MIN.	MAX.	MIN.	MAX.	
D	.189	.196	4.80	4.98	16 AA
S	.0020	.0070	0.05	0.18	
X	.107	.123	2.72	3.12	
D	.337	.344	8.56	8.74	20 AB
S	.0500	.0550	1.270	1.397	
D	.337	.344	8.56	8.74	24 AC
S	.0250	.0300	0.635	0.762	
D	.386	.393	9.80	9.98	28 AD
S	.0250	.0300	0.635	0.762	
X	.271	.287	6.88	7.29	

VARIATIONS:

NOTES:

- D & E DO NOT INCLUDE MOLD FLASH OR PROTRUSIONS.
- MOLD FLASH OR PROTRUSIONS NOT TO EXCEED .006" PER SIDE.
- HEAT SLUG DIMENSIONS X AND Y APPLY ONLY TO 16 AND 28 LEAD POWER-QSOP PACKAGES.
- CONTROLLING DIMENSIONS: INCHES.
- MEETS JEDEC MO137.

MAXIM  
PROPRIETARY INFORMATION  
TITLE:  
PACKAGE OUTLINE, QSOP, .150", .025" LEAD PITCH  
APPROVAL DOCUMENT CONTROL NO. REV C 1/1  
21-0055

Maxim cannot assume responsibility for use of any circuitry other than circuitry entirely embodied in a Maxim product. No circuit patent licenses are implied. Maxim reserves the right to change the circuitry and specifications without notice at any time.

Maxim Integrated Products, 120 San Gabriel Drive, Sunnyvale, CA 94086 408-737-7600 11